

## MOD 4 – ASSEMBLY INSTRUCTIONS

### Parts List

- A** - 2 x Main Beams, scarfed both ends, pre-drilled – 2.7mtrs Length
- B** - 4 x Cross Rafter, scarfed both ends – 2.7mtrs Length
- C** - 4 x Posts, Notched and Pre-Drilled - 2.4mtrs Length
- D** - 8 x Struts Pre-Drilled
- E** - 16 x Angle Brackets
- F** - 4 x Coach Bolt Sets (bolt, washer and nut)
- G** - 96 x Wood Screws (for angle brackets) 25mm x No.8
- H** - 16 x Wood Screws (for struts) 50mm x No.8
- I** - 4 x Post Fixings (Spike, Concrete-In or Bolt-Down incl. ankerbolts)

Fig 1. - Module 4

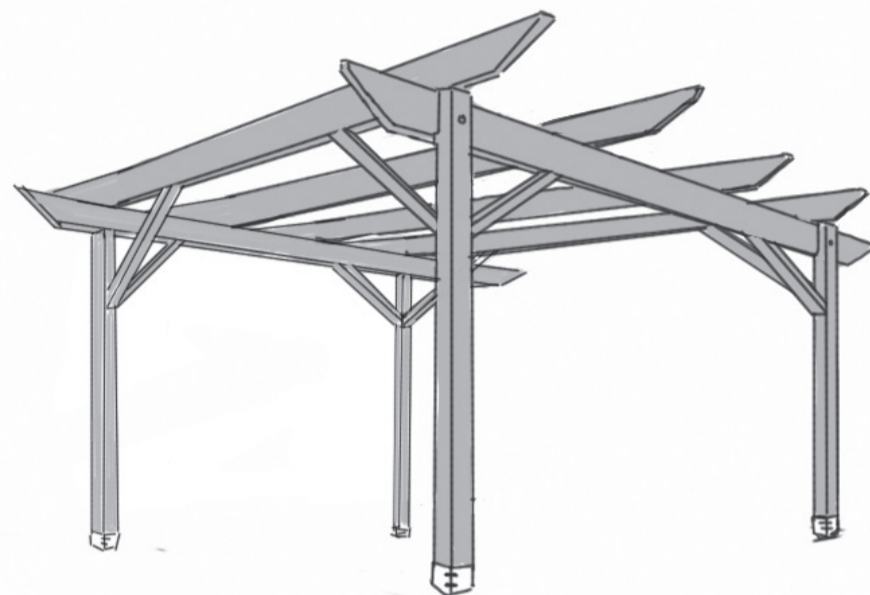

Fig 2. - Marking Out Post Positions

With a measure make sure lines A and B are the same length.

\* N.B.: Please take measurement dimensions to CENTRE of post fixings.

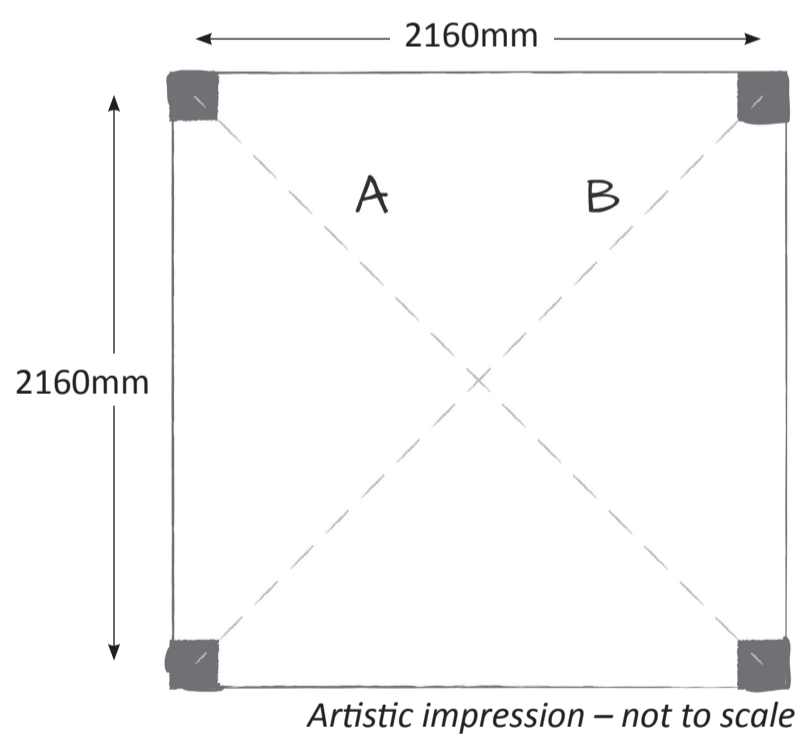
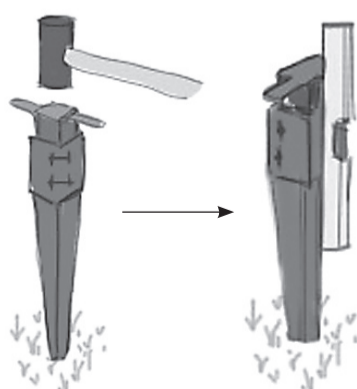
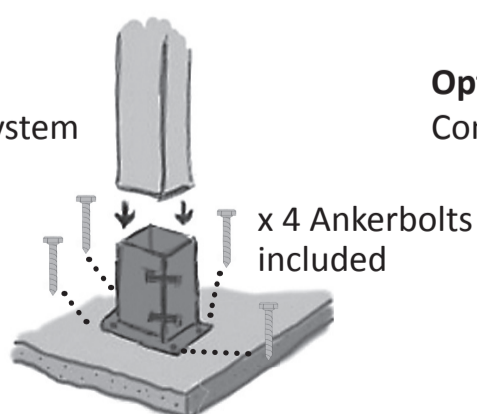

Fig 3. - Fitting of Post Supports

**Option 1:**  
Original Spiked System



**Option 2:**  
Bolt Down System



**Option 3:**  
Concrete-in System

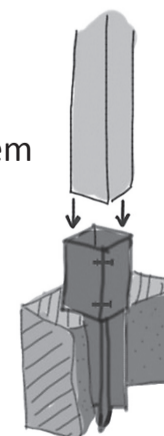

Fig 4. - Fitting Main Beam

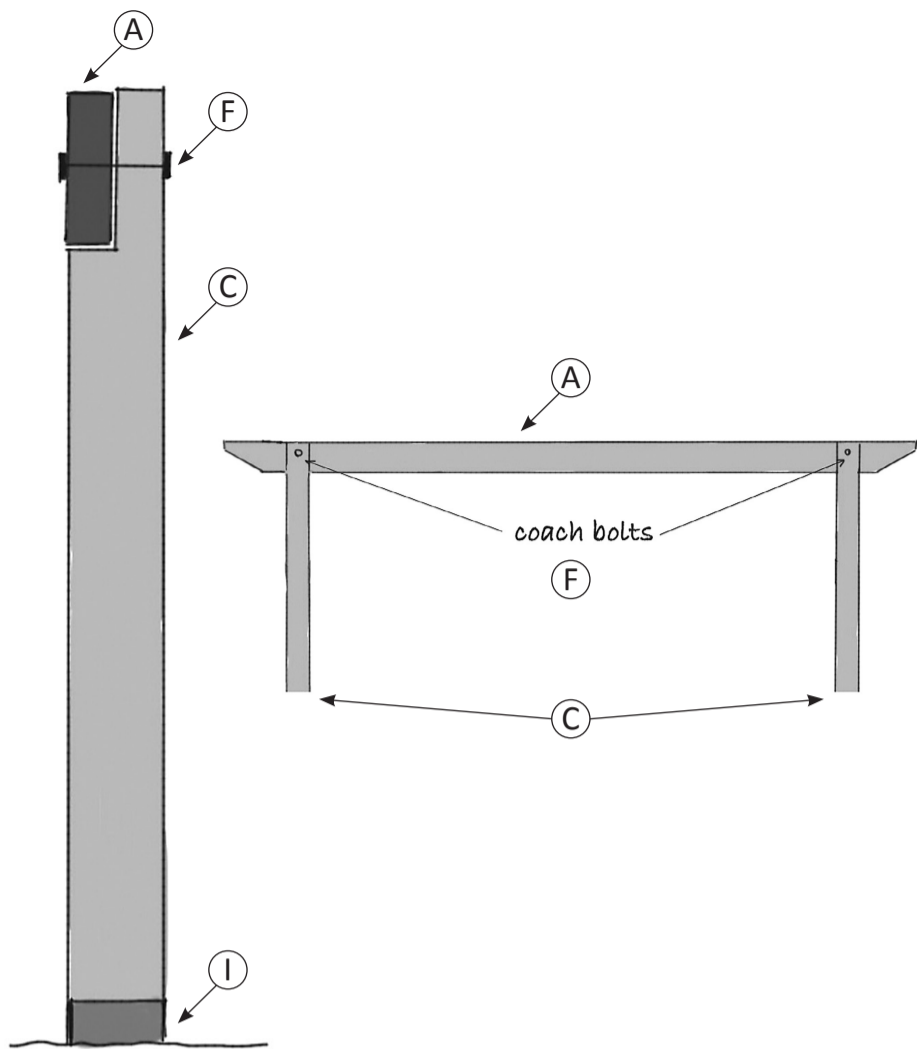

Fig 5. - Attaching Cross Rafter to Main Beam

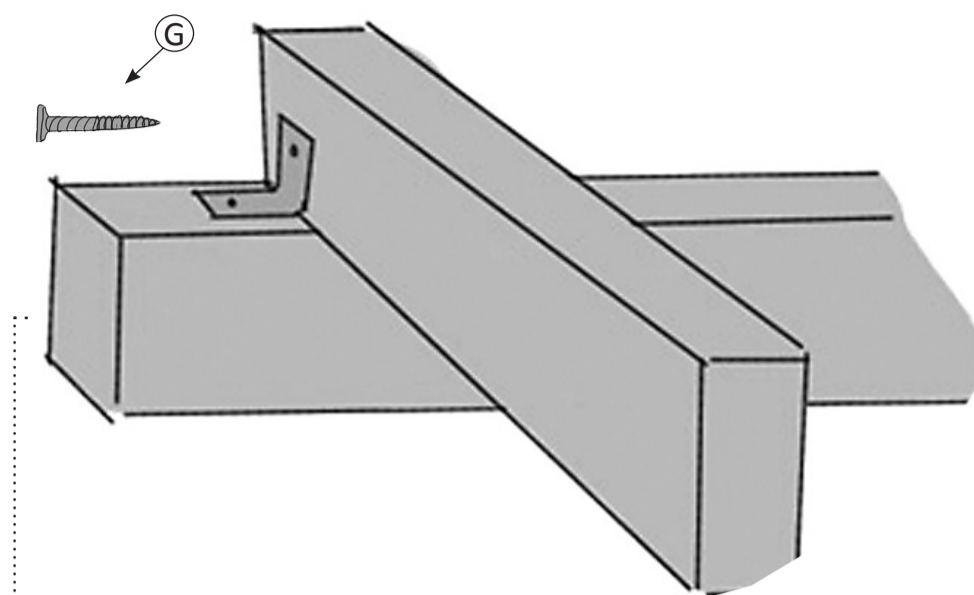

Fig 6. - Fixing Struts

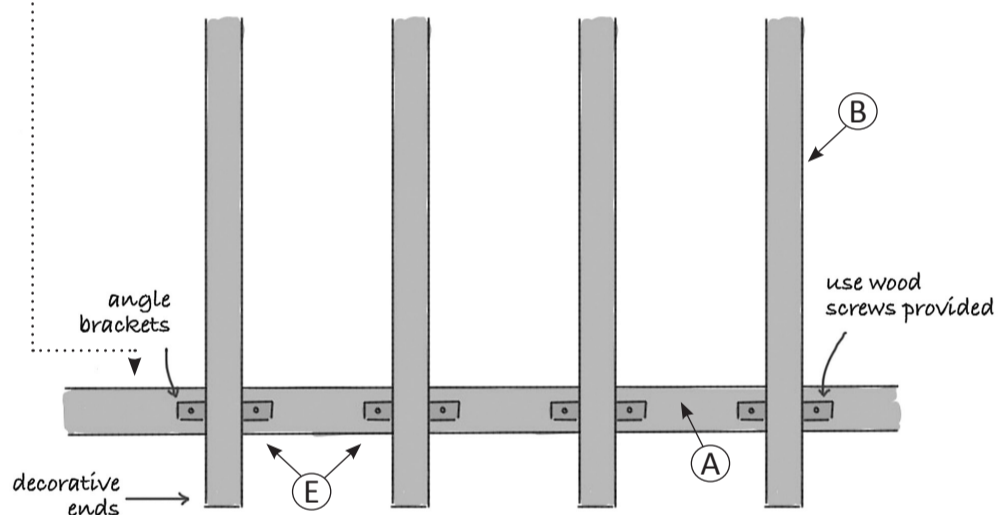
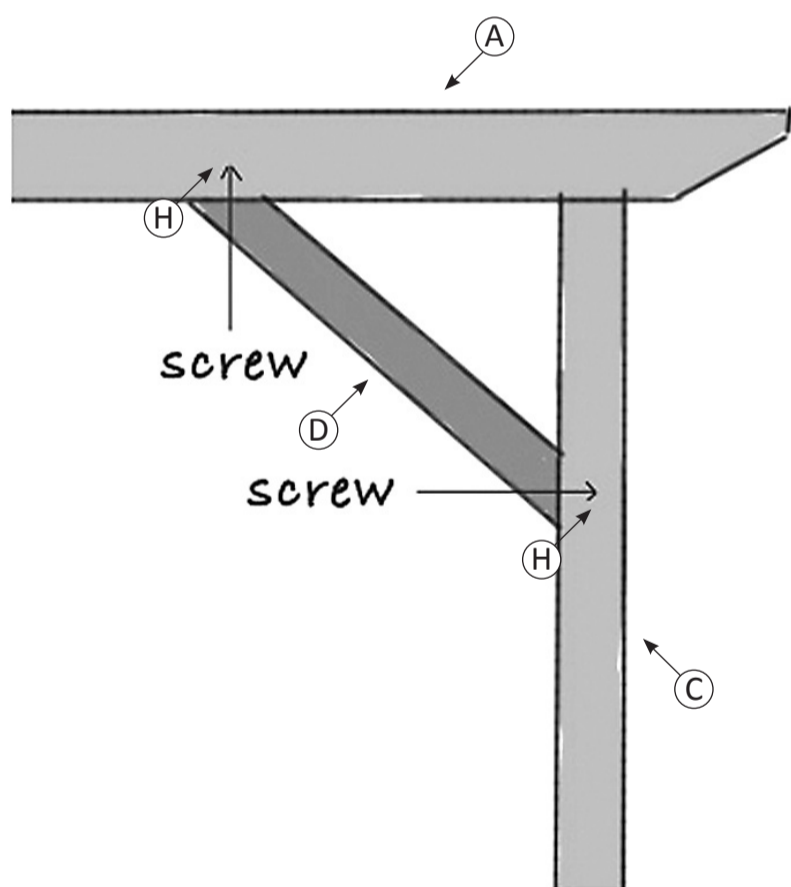

Fig 7. - Finish

As some of the screws & bolts may have become loose during assembly, it is important to re-check that they are tight and ensure they are securely fastened.